



April 19, 2002

DN-5306 • H-114

LPX-751

Very Intelligent Early Warning (VIEW®) LASER Smoke Detector

Section: Intelligent/Addressable Devices

GENERAL

The NOTIFIER LPX-751 VIEW® Laser Detector provides a revolutionary advance in early warning smoke detection technology. The unique design of this detector, combined with enhanced AWACS™ algorithms in the NOTIFIER AFP-300, AFP-400, AFC-600, or NFS-640 control panel, allows smoke detection sensitivity that is 10 to 50 times higher than present photoelectric technology. Because of this high sensitivity, the LPX-751 can provide very early warning of slow smoldering fires. Its performance is comparable to present aspiration technology, at a substantially lower installed cost.

The LPX-751 uses an extremely bright laser diode, combined with special lens and mirror optics (*U.S. patent pending*), to achieve a signal-to-noise ratio that is much higher than traditional photoelectric sensors. In addition, the tightly focused light beam, combined with the AWACS™ algorithms (*U.S. patent pending*), allow the system to differentiate between dust and smoke particles. Because of this differentiation, the LPX-751 can be set to extremely high sensitivity, yet can reject false signals caused by larger airborne particles such as dust, lint, and small insects (*U.S. patents pending*).

The LPX-751 is an intelligent (analog/addressable) detector using standard NOTIFIER protocol. Up to 99 LPX-751 detectors may be installed per AFP-300/-400, AFC-600, or NFS-640 loop. It may be mixed in any combination with other NOTIFIER intelligent sensors on the same loop and is quickly installed using the panel autoprogram feature. The LPX-751 provides dual bi-color LEDs, which blink green in normal operation and illuminate steady red in alarm.

Using the enhanced AWACS™ algorithms, the VIEW® system provides drift compensation (meeting UL requirements as a calibrated sensitivity meter), maintenance alert (3 levels), selection of 9 alarm levels and 9 pre-alarm levels, and report of drift compensation used and recent peak values. The system includes a self-learn sensitivity adjustment to set the pre-alarm level just above the peak levels sensed over long periods of time for each detector's actual environment. The system includes multi-detector algorithms (*U.S. patent pending*) that permit one sensor to consider readings from adjacent sensors to provide faster detection of fires.

FEATURES

- Very Intelligent Early Warning (VIEW®) smoke detection.
- Advanced laser light source and patented optical design.
- Sleek low-profile housing (1.66"/42.164 mm height).
- NOTIFIER Analog Addressable communications protocol provides extremely reliable operation proven in millions of worldwide detector installations.
- Sensitivity to 0.03%/foot.

VIEW® is a registered trademark of NOTIFIER.



California State Fire Marshal
7272-0028:187



MEA
72-97-E



5306p1.jpg



5306p2.jpg



6714recs.jpg

LPX-751 with B710LP base (top), B501 base (middle), and RMK400 recessed mounting kit (bottom).

- Low standby current allows 99 devices per two-wire loop in addition to 99 modules.
- Rotary decade switches allow quick selection of address without resorting to binary switches, special programmers, or bar coding devices.
- Dual LED design provides 360° viewing angle.
- Two-color LEDs blink green for normal, steady red for alarm.
- Built-in magnetic test switch, or automatic test commanded from panel.
- Optional relay, isolator, or sounder bases.

NOTIFIER® is an operation of Honeywell.

This document is not intended to be used for installation purposes. We try to keep our product information up-to-date and accurate. We cannot cover all specific applications or anticipate all requirements. All specifications are subject to change without notice. For more information, contact NOTIFIER. Phone: (203) 484-7161 FAX: (203) 484-7118



12 Clintonville Road, Northford, Connecticut 06472



SPECIFICATIONS

Operating voltage range: 15 to 28 VDC.

Maximum standby current: 230 μ A @ 24 VDC (no communication).

Maximum average standby current: 255 μ A @ 24 VDC (one communication every 5 seconds with LED blink enabled).

B224RB/B224BI: < 700 μ A @ 24 VDC (includes detector).

Maximum alarm current: 6.5 mA @ 24 VDC (LED "ON").

Operating humidity range: 10% to 93% Relative Humidity, non-condensing.

Operating temperature range: 0° to 49°C (32° to 120°F).

Loop resistance: 40 ohms maximum.

Dimensions: *Height:* 1.66 inches (42.16 mm) installed in B710LP base. *Diameter:* 6.1 inches (154.94 mm) installed in B710LP base; 4.1 inches (104.14 mm) installed in B501 base. *Weight:* 3.6 oz. (102 g).

BASES AVAILABLE:

B710LP: 6.1 inches (154.94 mm) diameter.

B501: 4.1 inches (104.14 mm) diameter.

B501BH: Sounder base assembly. Includes B501 base.

B224RB Relay Base: *Screw terminals:* Up to 14 AWG (2.00 mm²). *Relay type:* Form-C. *Rating:* 2 A @ 30 VDC resistive; 0.3 A @ 110 VDC inductive; 1.0 A @ 30 VDC inductive. *Dimensions:* 6.2 in. (157.48 mm) x 1.2 in. (30.48 mm).

B224BI Isolator Base: *Dimensions:* 6.2 in. (157.48 mm) x 1.2 in. (30.48 mm). *Maximum:* 25 devices between isolator bases.

RECOMMENDED COVERAGE PER DETECTOR

In order to support sophisticated smoke/dust discrimination algorithms (cooperating multi-detector), it is recommended that at least two LPX-751 detectors be installed in each room or enclosed area.

Recommended coverage per detector is 400 square feet (37.16 square meters).

INSTALLATION

The LPX-751 plug-in detector uses a separate base to simplify installation, service, and maintenance. A special tool allows maintenance personnel to plug-in and remove detectors without using a ladder.

Mount base on a box which is at least 1.5" (38.1 mm) deep. Suitable mounting base boxes include:

- 4" (101.6 mm) square box.
- 3-1/2" (88.9 mm) or 4" (101.6 mm) octagonal box.
- Single-gang box (except relay or isolator base).

ORDERING INFORMATION

LPX-751 Laser Detector. Intelligent laser sensor. Mounts to one of the bases listed below.

LPX-751A Same as above except Canadian version.

BASES:

B710LPBP Standard U.S. Low-Profile Base, package of ten (10).

B501BP Standard European Flangeless Base, package of ten (10).

B501BH Sounder Base, includes B501 Base.

B224RB Intelligent Relay Base.

B224BI Intelligent Isolator Base. Isolates SLC from loop shorts.

ACCESSORIES:

F110 Retrofit Replacement Flange for BX-501 base.

RA400Z *Remote LED Annunciator. 3 - 32 VDC. Fits U.S. single-gang electrical box.

MOD400R Detector Sensitivity Test Tool. Use with most analog or digital multimeters. Satisfies requirement of NFPA72 for sensitivity testing.

SMK400 Surface Mounting Kit provides for entry of surface wiring conduit. *For use with B501 base only.*

RMK400 Recessed mounting kit. *For use with B501 base only.*

M02-04-01 Test Magnet.

M02-09-00 Test magnet with telescope stick.

XR-2 Detector Removal Tool. Allows installation and/or removal of 700 Series detector heads from base in high ceiling installations.

XP-4 Extension Pole for XR-2. Comes in three 5-ft. (1.524 m) sections.

**Supported by B710LP and B501 bases only.*

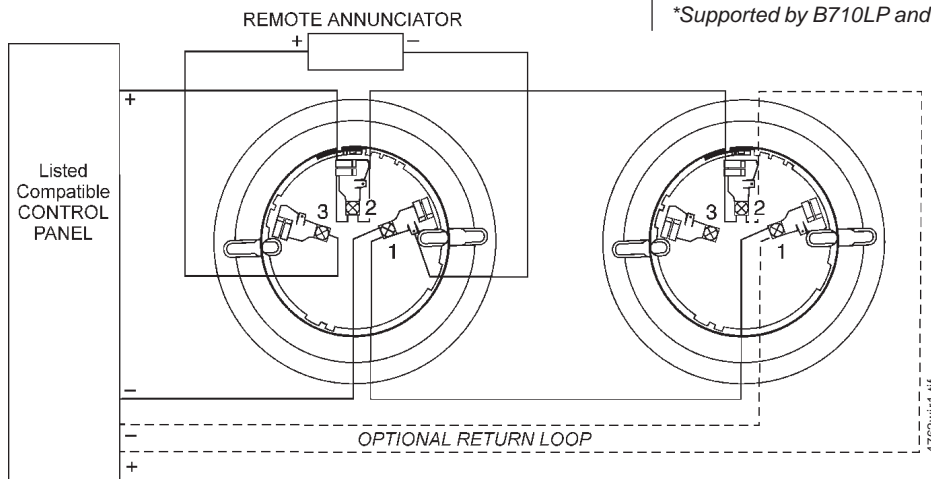

**Wiring Diagram
(standard base)**

LPX-751 DESIGN

The LPX-751 incorporates an extremely bright laser diode and integral lens that focuses the light beam to a very small volume near the receiving photo sensor. The light then passes into a light trap and is absorbed. The photo sensor is activated by a scattering of smoke particles in this small-volume light beam.

In a typical photoelectric detector, the light beam is very wide and can reflect off the chamber walls into the photo sensor because dust accumulation changes the wall color from flat black to gray. With the LPX-751, the concentrated light beam does not touch the walls, therefore it is much less susceptible to dust accumulation.

Smoke scatters light in all directions and, in a typical photoelectric detector, only a small portion of that scattered light reaches the photo sensor itself. In the LPX-751, a special mirror reflects and concentrates most of the scattered light into the photo sensor. See laser detail drawings on this page.

Compared to smoke, airborne dust particles are very large and very sparse. Since a) they are in motion; b) the illuminated volume is very small; and c) the LPX-751 flashes the laser only every few seconds; then the occasional dust particle cannot remain in the light volume for more than one or two samples. This transient signal from dust is the key to the dust discrimination performed by VIEW®.

